

Very Large Floating Structures Can Help Congested Ports Meet Goods Movement and Offshore Wind Turbine Deployment Needs

By **Reece Shaw**

Financial and environmental considerations, including shallow channels or expensive retrofitting projects, may limit a port's ability to increase throughput and functionality. A very large floating structure (VLFS) can serve this purpose by supporting the staging and integration, manufacturing and fabrication, and operations and maintenance of floating wind turbine generators (WTGs). Subsequently, the VLFS can be decommissioned and repurposed as a container transfer terminal.

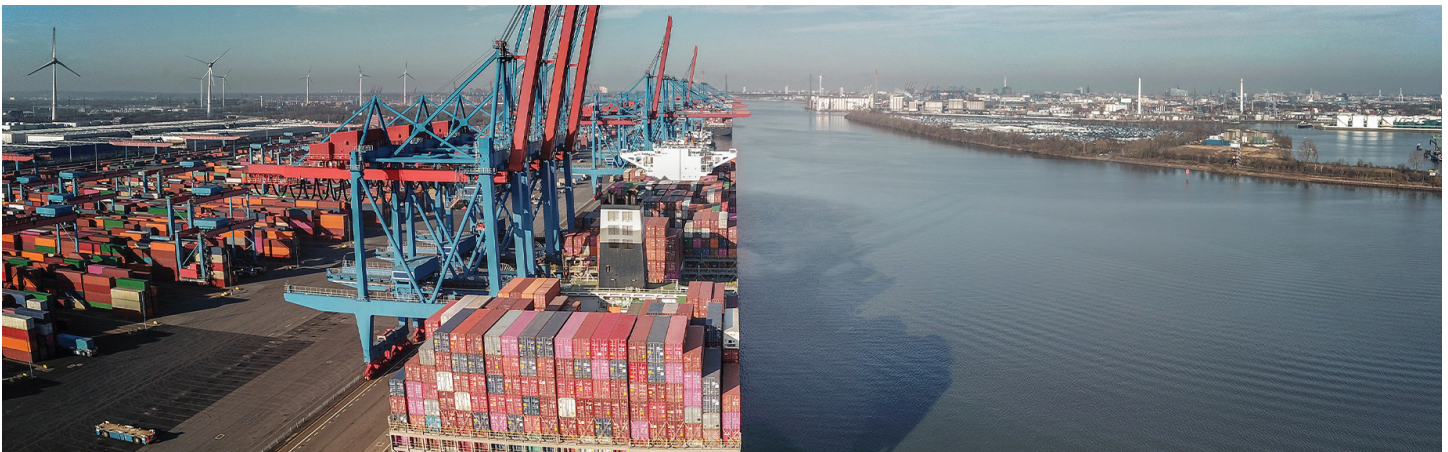

Many ports around the world cannot accommodate very large container vessels (VLCVs) due to ship-to-shore crane height and reach restrictions, as well as the draft of container vessels. When accounting for high cost and environmental impacts, it is often prohibitive, if not impossible, to deepen access channels and harbors, and retrofit quays and topside cranes. Additionally, to create greener and more efficient facilities, ports are maximizing train delivery of containers to and from ships because this is the most sustainable and efficient way to move cargo. In some cases, these same ports would use their facilities for floating WTG support, if they could.

Accounting for these factors, a modular floating terminal that can be configured to address a port's specific needs has been developed. Using a port's existing infrastructure and facilities, the floating terminal leverages offshore deep water, has a

limited environmental impact, is impervious to sea-level rise and can be rapidly implemented.

Using a floating terminal to transfer containers to and from VLCVs significantly increases the potential delivery of containers to and from ships by train and reduces container double handling due to bundling and direct-to-rail loading. When the floating terminal is used for offshore wind turbine staging and integration, manufacturing and fabrication, and operations and maintenance, the structure can be configured to support building various floating foundations, including barge, spar buoy and different tension-leg types, and semi-submersibles (Figure 1), as well as the towers supporting the WTGs. Finally, the floating terminal can be repurposed as a container transfer facility upon decommissioning.

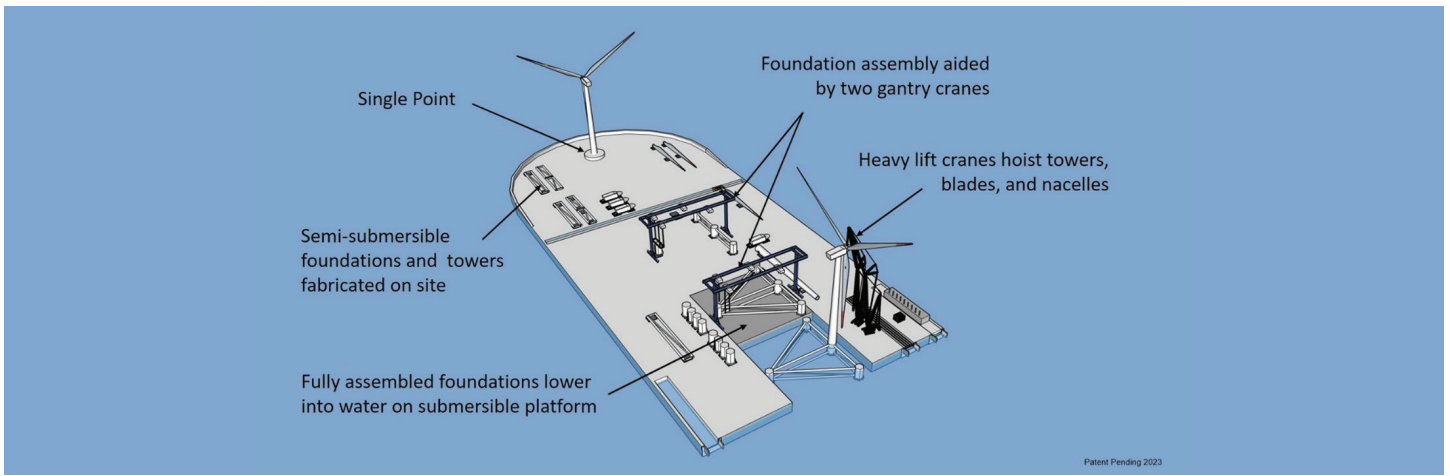

Figure 1: A modular floating structure configured for semi-submersible offshore wind turbine staging and integration, and manufacturing/fabrication.

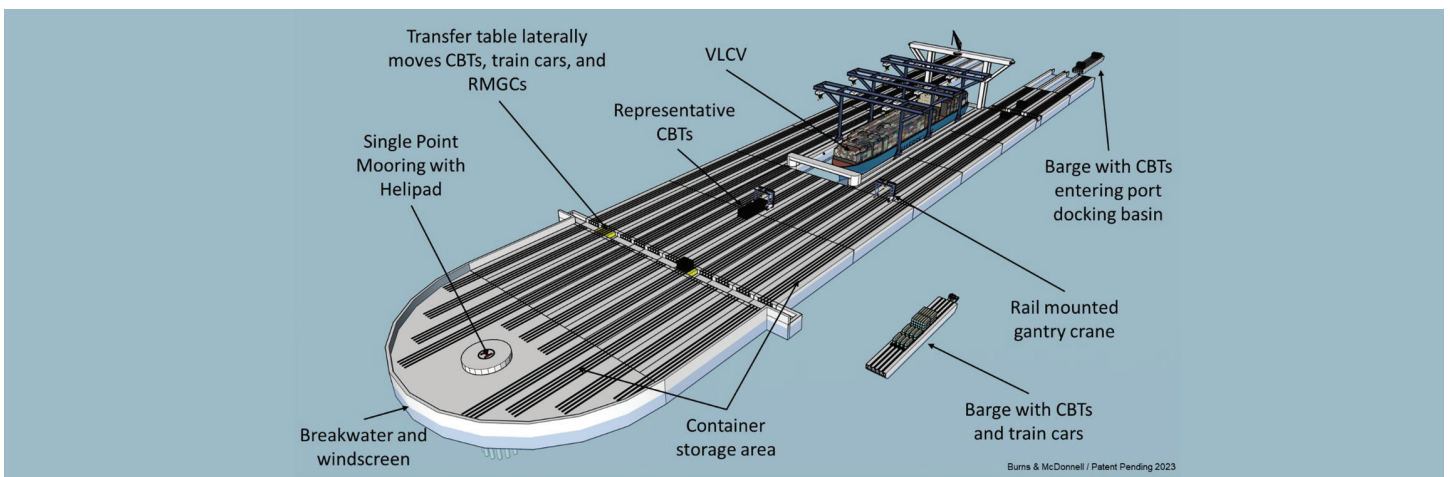

Figure 2: Concept Ocean FASST pivoting about a single point mooring tower.

For the purposes of illustration, the following VLFS concepts are container transfer configurations. These illustrations do not

address staging and integration, manufacturing and fabrication, and operations and maintenance for floating WTGs.

Two Types of Floating Terminals

There are two types of floating terminals: the Ocean Floating Automated Ship-to-Ship Terminal (Ocean FASST), which is designed for open water, and the Harbor FASST, which is designed for sheltered water. Both versions can be built to support the floating OSW turbine industry.

A FASST is designed to berth a single 24,000-TEU (20-foot-equivalent) VLCV, a Chinamax bulk carrier, or alternatively, two Panamax vessels simultaneously. Within this context, cargo handled at the terminals would be containerized including containerized bulk. Containers can be transported to and from offshore terminals via barges. However, oversized cargo that can't fit inside a 40-foot

container because the cargo is too long, too high or too wide can be delivered directly to a FASST via conventional marine vessels.

Ocean FASST

Stationed offshore in deep water, the container transfer Ocean FASST (Figure 2) is connected to a single point mooring, which serves as a weathervaning link with connections between the terminal and requisite geostatic subsea shore-connections. The Ocean FASST is designed to self-orient itself by aligning with the combined forces of wind, waves and currents. This orientation enhances the terminal's operational efficiency. Depending on the water depth, various mooring configurations can be integrated into the terminal.

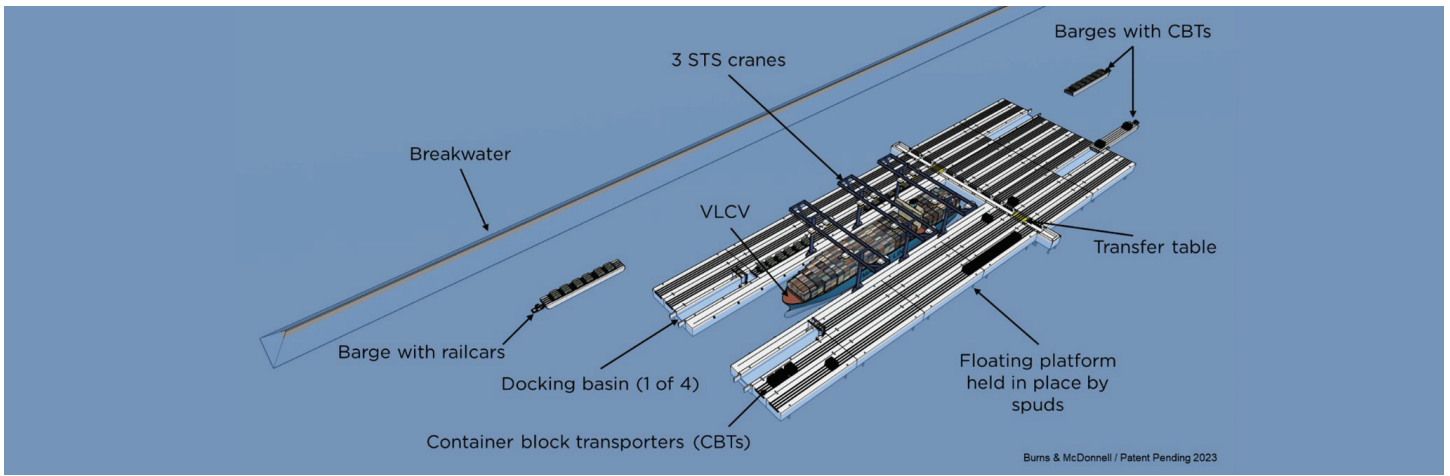

Figure 3: Concept Harbor FASST is held in position by spuds.

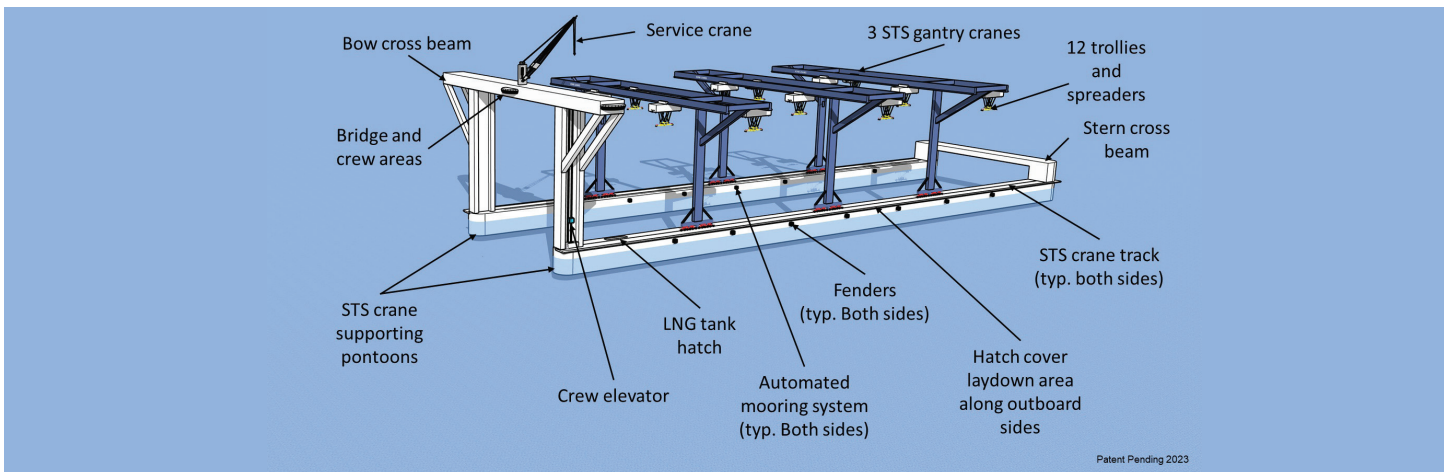

Figure 4: Catamaran vessel with three STS gantry cranes.

Harbor FASST

The primary distinction between the Harbor FASST and the Ocean FASST involves mooring protocols. Located in a port's sheltered water, adjacent to the main shipping channel, the Harbor FASST is held in the horizontal plane by retractable spuds while allowing it to float.

Elements of the FASST System

FASST systems comprise various combinations of the following eight elements:

- Catamaran vessel.
- Ship-to-ship gantry cranes.
- Floating platform.
- Single point mooring (SPM) system.
- Vacuum monitoring system.
- Container block transporters (CBT) system.

- Purpose-built yard engines.
- Purpose-built barges.

The subsequent descriptions of each element explain how they interact with each other to create an operable FASST system.

Catamaran Vessel

Depending on the geoeconomics and metocean conditions pertinent to the potential site of the FASST, a catamaran vessel is a viable option. The catamaran vessel (Figure 4) will be built in a shipyard and self-propelled or towable. It incorporates two pontoons bridged together to support three straddling ship-to-ship gantry cranes. Depending on what a port needs, the catamaran vessel could have onboard generation capabilities powered by liquefied natural gas, green ammonia or hydrogen which is stored in exchangeable ISO tank containers. A sufficient distance between the

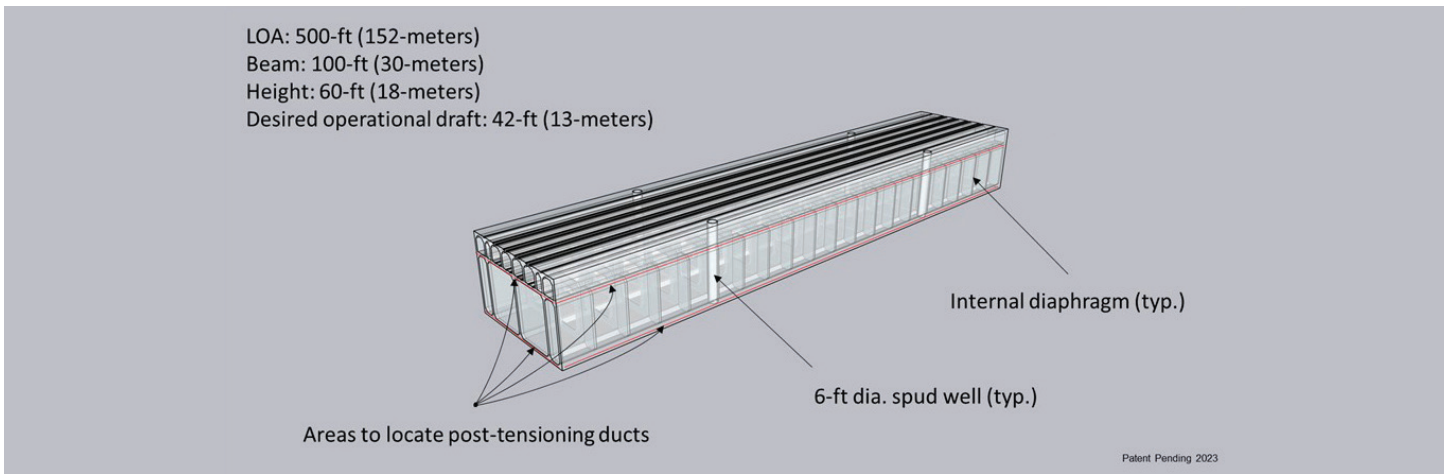

Figure 5: Representative prestressed and precast platform units which are post-tensioned together at the site.



Figure 6: Container block transporter (CBT).

pontoons facilitates tug assisted maneuvering of visiting vessels and bunkering services.

Ship-to-Ship Gantry Cranes

The three symmetrical wide span STS rail-mounted gantry cranes will straddle the catamaran and move along the top of the pontoons. With four spreaders on each crane, the system will have the capacity to handle 12 containers simultaneously, supporting an annual throughput capacity of more than 2 million TEUs.

Floating Platform

A FASST platform is constructed using a set of modular precast, prestress, post-tensioned components. These components are built remotely, towed to the site and assembled in stages. There are three main types of precast components: platform units (Figure 5), docking basin units and transfer table units. In the case of the Ocean FASST, there are also bow units that provide a dual purpose as a breakwater/windscreen and as the pivotal connection with the SPM anchoring system.

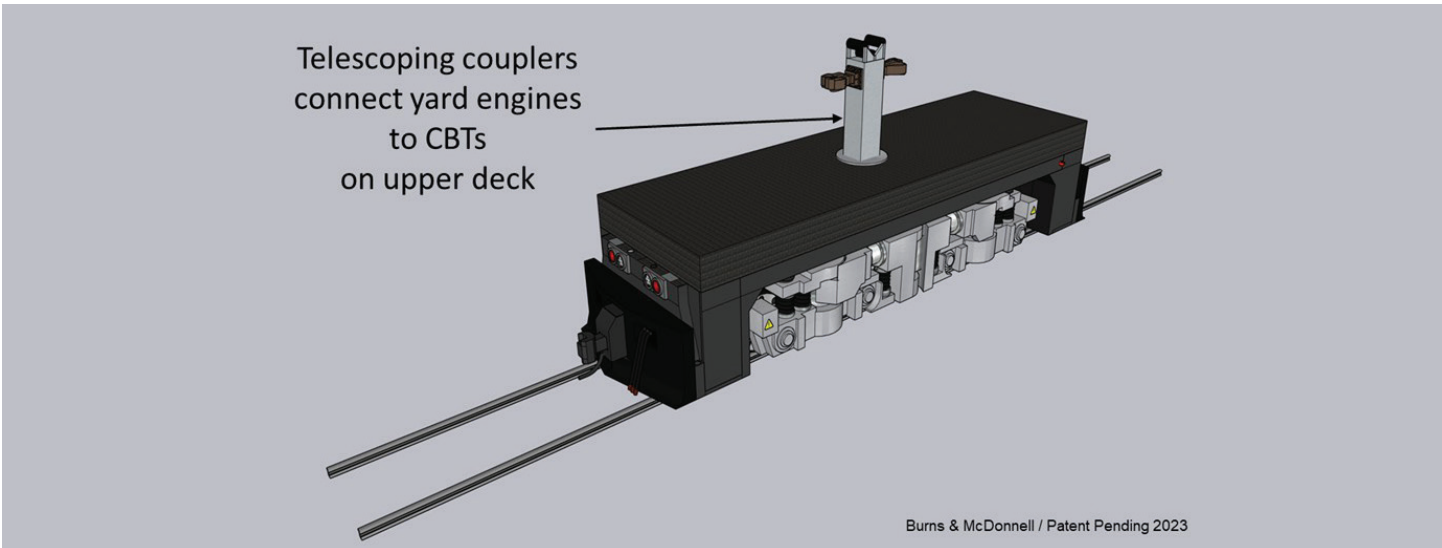

Figure 7: The purpose-built yard engines run on the below deck.

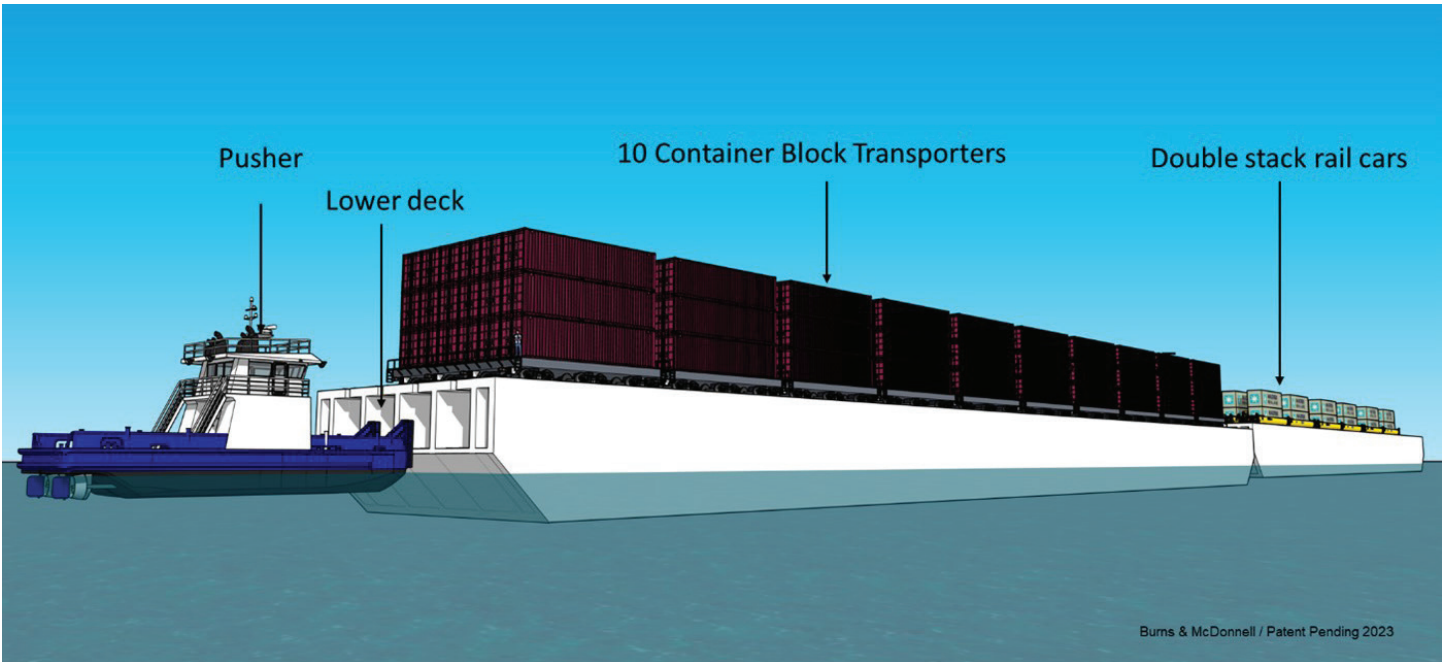

Figure 8: A purpose-built barge with 10 CBTs (left) and one with double stack railcars (right).

Single Point Mooring System

The SPM tower mooring system incorporates a tower structure that is permanently fixed to the seabed by means of piles or a spread mooring system using multiple mooring lines. The spread mooring system is intended for deep-water environments. The SPM integrates a bearing system that enables the platform to rotate around the stationary geostatic section.

motion between the visiting vessel, catamaran vessel and platform. This vacuum system enables rapid mooring and releasing of vessels, which drastically reduces vessel motion, enhances cargo transfer efficiency, improves loading and offloading productivity, and supports overall safety. This mooring system also has the capability to slightly adjust the position of the visiting vessel, thus aligning the STS cranes accurately over the containers.

Vacuum Mooring System

A Cavotec NxG mooring system, or similar solution, can be used to achieve effective connectivity while minimizing

Container Block Transporter System

CBTs are specifically designed to minimize container rehandling, with each able to hold 18 individual containers



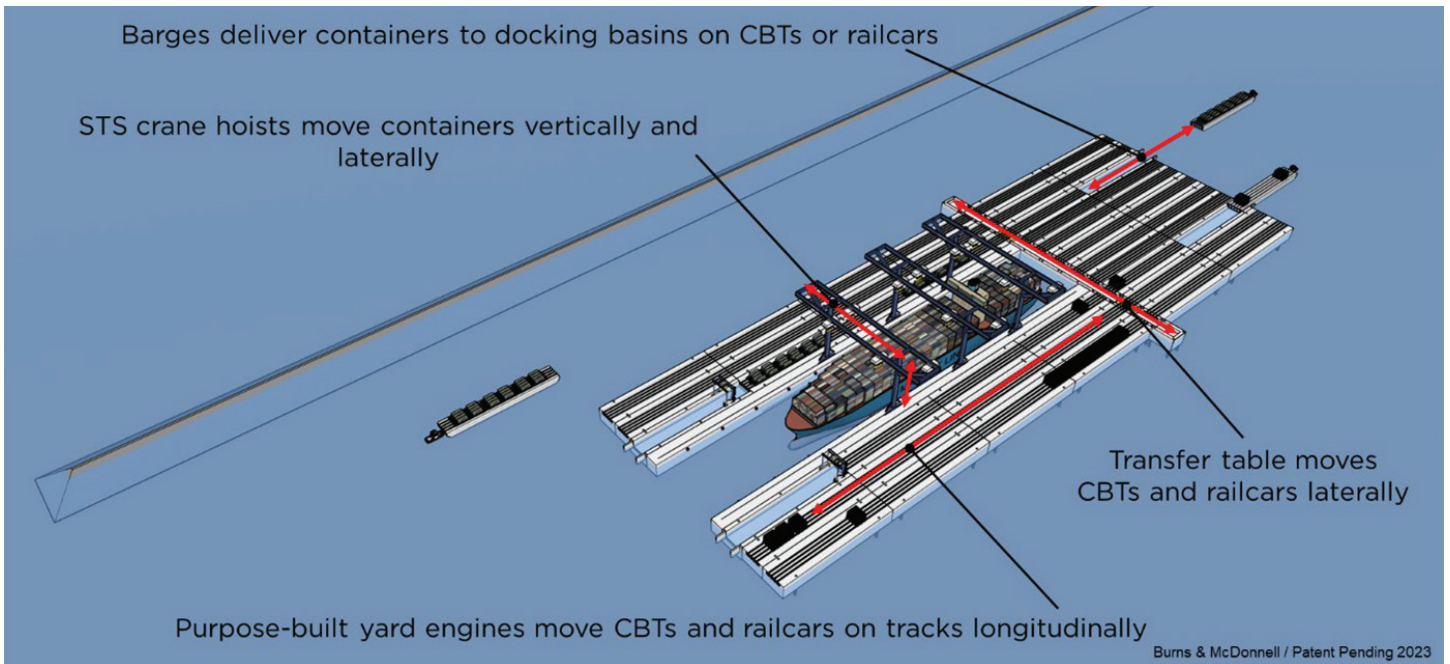

Figure 9: Container movement on the FASST.

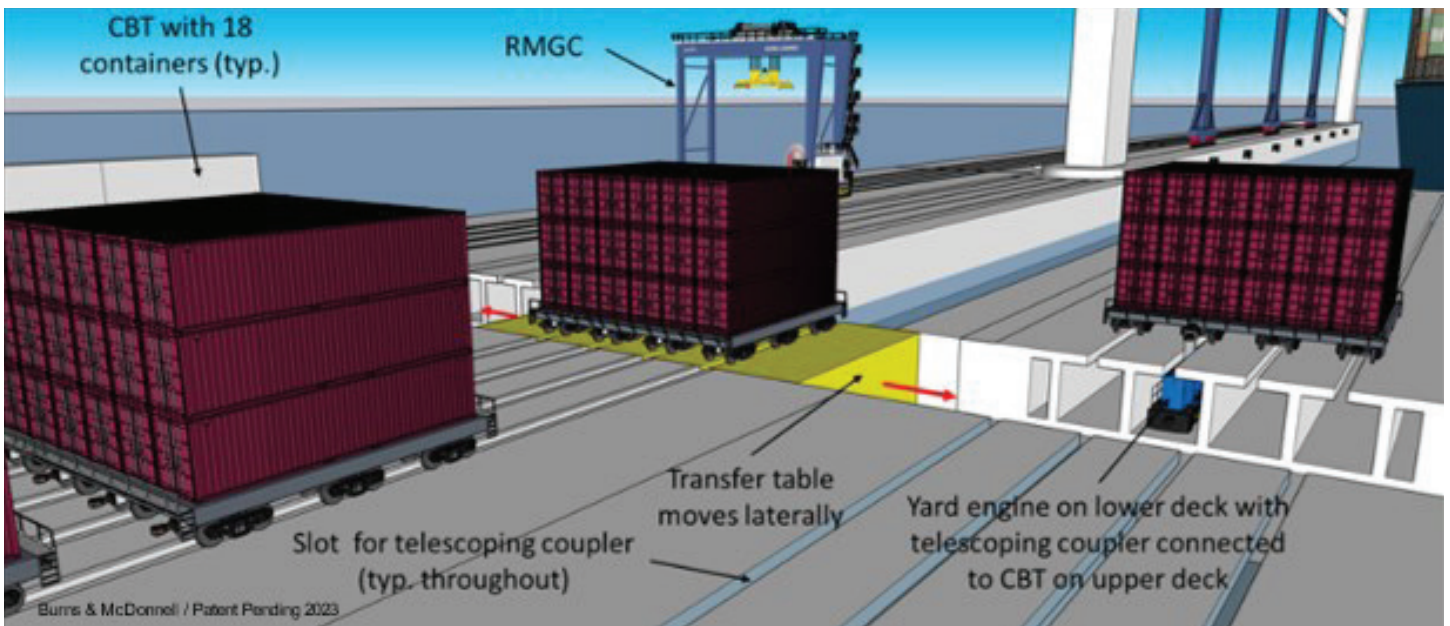

Figure 10: The container block transports are moved laterally by a rolling transfer table and longitudinally by yard engines which run on the deck below.

measuring 40 feet long. The dimensions of the CBTs are 15 meters (50 feet) in length and 12 meters (40 feet) in width. CBTs are equipped with couplers and brakes for efficient operation. The transporters ride on 12 rail-car trucks distributed across four sets of standard-gauge railroad tracks. Therefore, the purpose-built barges and the platform itself are equipped with sets of four parallel tracks. These tracks allow for direct loading and unloading of containers to and from rail

cars when rail cars are placed on the barges and brought to the offshore platform.

Purpose-Built Yard Engines

CBTs can be moved either as unit trains or individually using battery electric yard engines that travel on the lower deck of the platform. This setup allows the yard engines to move freely while also positioning the CBTs under the STS cranes

or onto the barges. The yard engines are equipped with a telescoping (retractable) coupler mechanism. By retracing the coupler arm, the yard engine can pass beneath the CBTs. Thus, when a yard engine arrives at a CBT that needs to be moved, the telescoping coupler can be extended through a slot in the main deck tracks and connected to the CBT. Multiple yard engines can work in tandem to move a barge load consisting of 10 CBTs — equivalent to 180 containers.

Purpose-Built Transport Barges for Railcars and CBTs

Towable harbor or oceangoing barges can shuttle CBTs or rail cars loaded with containers between the FASST and the shoreside hub. These transport barges are specifically designed to accommodate 180 containers, each measuring 40 feet long, on 10 CBTs. Alternatively, the transport barges can accommodate 48 containers, each measuring 40 feet long, on 24 rail cars. The barges are brought to the platform and berthed according to the configuration shown in Figure 8.

Once a barge is inside a docking basin, its gates are closed and water is pumped out, causing the barge to rest on the basin floor. This berthing method serves two purposes: stabilizing the barge and automatically aligning the railroad tracks on the barge with those on the platform.

Offshore Operations

Once the floating platform is fully assembled, it is joined together with the catamaran vessel. The design of the FASST enables the catamaran to detach from the platform and move to a secure site in the event of an anticipated typhoon. Meanwhile, the platform remains in place to ride out the storm as it is designed to withstand severe weather events.

Figures 9 and 10 illustrate the movement of CBTs or rail cars both longitudinally and laterally. Bulk materials can be exported using a container bulk handling system, such as the system developed by the Intermodal Solutions Group or a similar system. Purpose-built containers with removable lids can be lifted from a CBT and, using a dedicated “rotainer” spreader, are tipped into the ship’s hull. Moreover, a fully automated twist lock removal system can be used to minimize the risk of injuries, reduce costs and enhance productivity.

Conclusion

Port operators are contending with unique challenges to engineer efficiency, sustainability and resiliency into every project. Geopolitical systems, financial markets and customer demand are realigning supply chains, and ports have a critical role to play in logistics, shipping and product delivery, especially when efficiency is a priority. Additionally, port infrastructure operates like a small city, incorporating numerous interconnected pieces that can drive efficiency while facilitating power generation using floating wind turbines.

A VLFS is a novel solution that can increase throughput while mitigating potential congestion. This solution is especially helpful for ports that can’t accommodate large container vessels. The decision to invest in a terminal for floating container transfers and floating offshore WTG staging and integration, manufacturing and fabrication, and operations and maintenance depends on various factors, including:

- The availability of labor and the requisite supporting services.
- The projected volumes of freight or floating WTGs traversing the facility.
- An objective evaluation of the hosting port’s unmet logistics needs.
- The efficiency and cost-effectiveness of processing containers or completed floating WTGs from the terminal into the supply chain or a wind farm.

These and other operational and market indicators are the basis upon which an investment decision can be formulated and evaluated when considering an offshore location versus a functionally comparable onshore coastal property.

About Burns & McDonnell



Burns & McDonnell is a family of companies bringing together an unmatched team of engineers, construction and craft professionals, architects, and more to design and build our critical infrastructure. With an integrated construction and design mindset, we offer full-service capabilities. Founded in 1898 and working from dozens of offices globally, Burns & McDonnell is 100% employee-owned. For more information, visit burnsmcd.com.